

LIQUID RECEIVERS

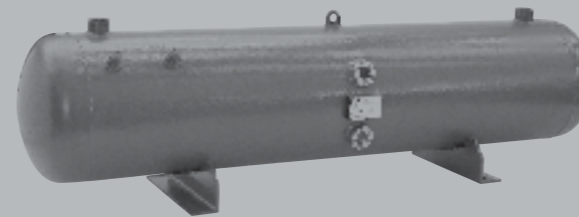

THERMOKEY

HORIZONTAL LIQUID RECEIVERS HRL RICEVITORI DI LIQUIDO ORIZZONTALI

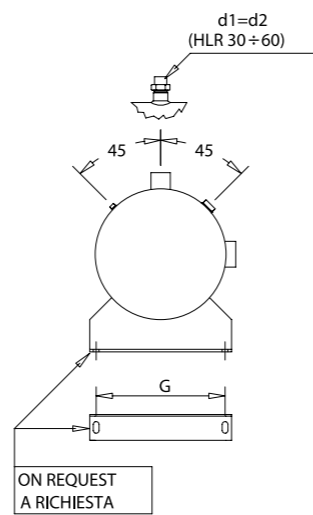
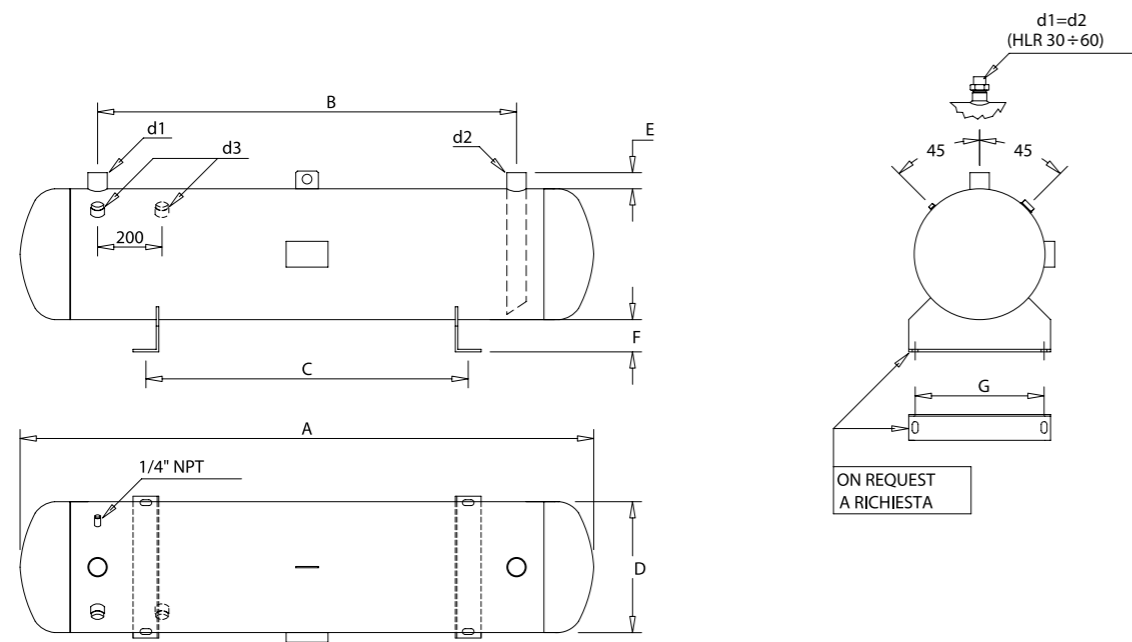

MODEL - MODELLO MODELL - MODELE	VOLUME dm ³	A mm	B mm	C mm	D mm	E mm	F mm	G mm	H mm	d1 mm	d2 mm	d3 mm	Category Categoria Kategorie Categorie * PED	Weight Peso Gewicht Poids
														Kg
HLR 30	31	920	550	560	219	70	80	260	-	ODS 35 (1"3/4 Rtlk)	ODS 35 (1"3/4 Rtlk)	1/2" NPT	II	35
HLR 40	40	1170	800	700									III	39
HLR 50	49	1420	1050	900									III	50
HLR 60	57	1670	1300	1000									III	56
HLR 70	64	1200	800	700	273	50	100	300	-	ODS 42	ODS 42	1" NP	III	52
HLR 80	77	1450	1050	900									III	68
HLR 90	90	1700	1300	1000									III	90
HLR 110	109	1480	1050	900	324	50	100	300	-	ODS 54	ODS 54	1" NPT	IV	91
HLR 130	128	1740	1300	1000									IV	108
HLR 145	144	1280	800	700	406	50	120	400	-	ODS 54	ODS 54	1" NPT	IV	120
HLR 175	173	1530	1050	900									IV	128
HLR 200	203	1780	1300	1000									IV	146
HLR 260	262	2280	1800	1200									IV	183
HLR 320	318	1830	1300	1000	508	50	120	400	-	OD 76	OD 76	2 x 1" NPT	IV	230
HLR 410	412	2330	1800	1200									IV	326
HLR 500	506	2830	2300	1500						IV	345			
HLR 600	600	3330	2800	2000						IV	420			
HLR 630	628	2850	2300	1500	558	70	120	500	-	OD 114	OD 114	3 x 1" NPT	IV	416
HLR 745	743	3350	2800	2000									IV	480
HLR 880	870	3380	2800	2000	610	70	120	600	-	OD 141	OD 141	3 x 1" NPT	IV	503
HLR 1000	999	3880	3300	2200									IV	605

* PED category according to EU directive 97/23-CE / The category refers to the use of group 2 fluids at the PS value of standard temperature version

Working limits - Limiti di lavoro (CE standard)

Design temperature - Temperatura di progetto: -10/+120°C / Design pressure - Pressione di progetto: 32 bar / Fluids - Fluidi: HFC, HCFC, NH3

VERTICAL LIQUID RECEIVERS VRL RICEVITORI DI LIQUIDO VERTICALI

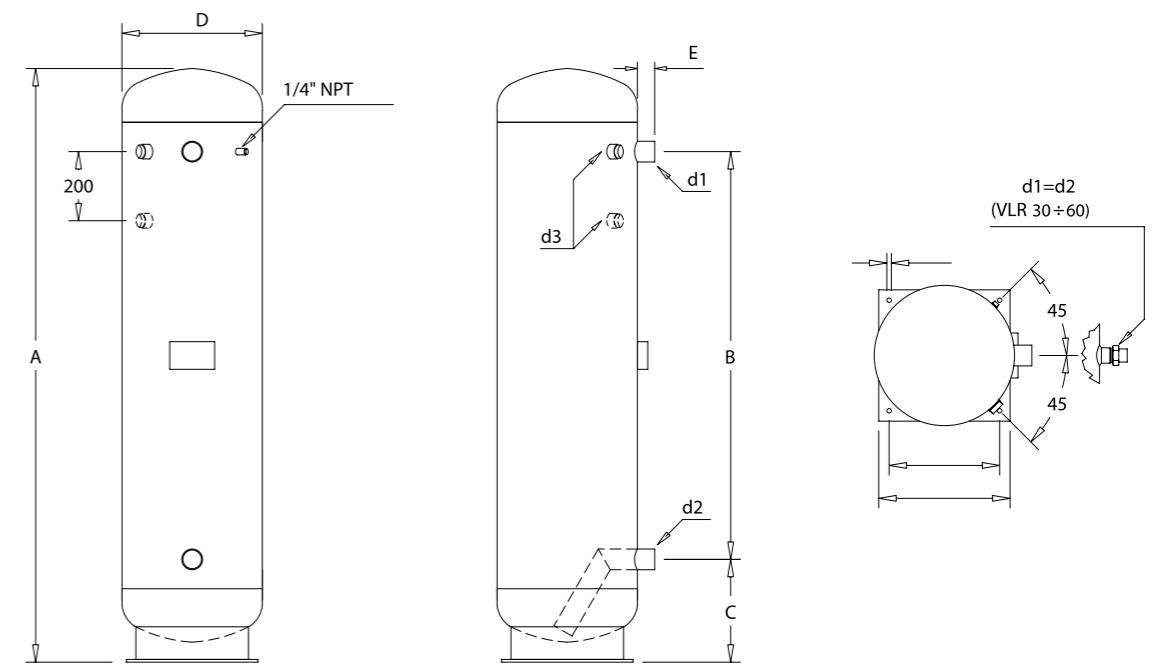

MODEL - MODELLO MODELL - MODELE	VOLUME dm ³	A mm	B mm	C mm	D mm	E mm	F mm	G mm	H mm	d1 mm	d2 mm	d3 mm	Category Categoria Kategorie Categorie * PED	Weight Peso Gewicht Poids
														Kg
VLR 30	31	950	550	215	219	70	270	210	13	ODS 35 (1"3/4 Rtlk)	ODS 35 (1"3/4 Rtlk)	1/2" NPT	II	37
VLR 40	40	1200	800										III	41
VLR 50	49	1450	1050										III	52
VLR 60	57	1700	1300										III	56
VLR 70	64	1230	800	230	273	50	270	210	13	ODS 42	ODS 42	1" NPT"	III	54
VLR 80	77	1480	1050										III	70
VLR 90	90	1730	1300										III	92
VLR 110	109	1520	1050	250	324	50	330	280	13	ODS 54	ODS 54	1" NPT	IV	94
VLR 130	128	1770	1300										IV	111
VLR 145	144	1330	800	290	406	50	380	320	13	ODS 54	ODS 54	1" NPT	IV	124
VLR 175	173	1580	1050										IV	132
VLR 200	209	1830	1300										IV	150
VLR 260	262	2330	1800										IV	187
VLR 320	318	1880	1300	315	508	50	500	440	18	OD 76	OD 76	2 x 1" NPT	IV	231
VLR 410	412	2380	1800										IV	330

* PED category according to EU directive 97/23-CE / The category refers to the use of group 2 fluids at the PS value of standard temperature version

Working limits - Limiti di lavoro (CE standard)

Design temperature - Temperatura di progetto: -10/+120°C / Design pressure - Pressione di progetto: 32 bar / Fluids - Fluidi: HFC, HCFC, NH3