



# ROTARY COMPRESSOR SPECIFICATION SHEET



三星电子

MODEL : 48B180JUBEH	SPEC. NO _____ :		
	DRAFT	CHECK	APPROVE

## 5. NOMINAL PERFORMANCE

Voltage (V)	240	-	-	Note
Cooling Capa. (Btu/h)	18,100	-	-	-
Running Current (A)	7.70	-	-	-
Input (W)	1,810	-	-	-
EER (Btu/W.h)	10.00	-	-	-
Noise (dBA)	58↓	-	-	Average of 4 point measurement at 90cm from surface
Vibration (μm)	130↓	-	-	Larger tangential vibration displacement at 90° & 180° points

## RATING CONDITION

Condensing Temperature ..... 54.4°C (130° F)

Evaporating Temperature ..... 7.2°C (45° F)

Return Gas Temperature ..... 35.0°C (95° F)

Liquid Temperature ..... 46.1°C (115° F)

Ambient Temperature ..... 35.0°C (95° F)

Compressor Cooling ..... 1 m/s air cooling

\* Return Gas Temp. for Noise & Vibration is 15.0°C (59° F)

## 6. GENERAL CHARACTERISTICS

No	Item	Characteristics
1	Operating voltage range	Within ±10% of the rated voltage
2	Starting voltage	No less than 85% of the rated voltage at compressor terminal in pressure balancing condition
3	Hydrostatic pressure rise	Max. 145 kg/cm <sup>2</sup> .G
4	Residual moisture/ Residual impurities	80 mg Max / 50 mg Max
5	Insulation resistance	50 MΩ min (with 500 V DC mega tester)
6	Withstand voltage	At 1800 V/sec(1250 v/min) Leakage current is less than 2.5 mA

# ROTARY COMPRESSOR



三星电子

## APPLICATION SHEET

MODEL : 48B180JUBEH	SPEC. NO _____ :		
	DRAFT	CHECK	APPROVE

No	Item	Operational standards and limits
1	Quantity of refrigerant charge	Split type : Max. 1,240 g / Window type : Max. 1,000 g (Need to the special discussion in case of excess)
2	Condensing temp (pressure)	28°C~65°C(10.50~26.51 kg/cm <sup>2</sup> .G)
3	Evaporating temp (pressure)	-25°C~+12.7°C(1.02~6.50 kg/cm <sup>2</sup> .G)
4	Compression ratio	2 ~ 8
5	Suction gas superheat	Sufficient superheat is proffered for preventing liquid flood back
6	Liquid subcool	Sufficient liquid subcool is proffered
7	Discharge gas temp.	Max. 115°C
8	Motor winding temp.	Max. 130°C
9	Bottom shell temperature	Min. 5 °C higher than condensing temp.
10	Abnormal pressure rise	Max. 48.0 kg/cm <sup>2</sup> .G
11	On-Off cycle	On/Off= Min. 3 Minutes / Min. 3 Minutes → Total 200,000 cycles
12	Oil level	Steady-state : higher than 5mm based bottom plane of cylinder Transient-state : higher than bottom plane of bottom flange
13	Vibration of tubing	Tubing vibration displacement : Max 0.8mm (±10% of rated voltage) If the resonance of the pipe can be checked, above condition is not necessary
14	Tube stress	Starting & stop : less than 3.5 kg/mm <sup>2</sup> Normal operating : less than 1.25 kg/mm <sup>2</sup>
15	Spacing of tubing	Between tube and moving parts : Min. 13.0 mm Between tube and non-moving parts : Min. 10.0 mm
16	Length of tubing	Max. 15m between indoor and outdoor sections (Need to the special discussion in case of excess)
17	Height difference of tubing	Max. 7m between indoor and outdoor sections (Need to the special discussion in case of excess)
18	Tilt of operation	The allowable tilt of compressor under operation should be 5° or less
19	Storage	Do not open compressor rubber plugs more than 10 minutes before use Max. storage time : 1 year from manufacturing
20	External shock	External shock should be less than 60 G
21	Prohibition of air or vacuum operating	Do not operate the compressor in air or vacuum

# ROTARY COMPRESSOR OUTDRAWING DIMENSION



三星电子

SPEC. NO			:
DRAFT	CHECK	APPROVE	

MODEL : 48B180JUBEH

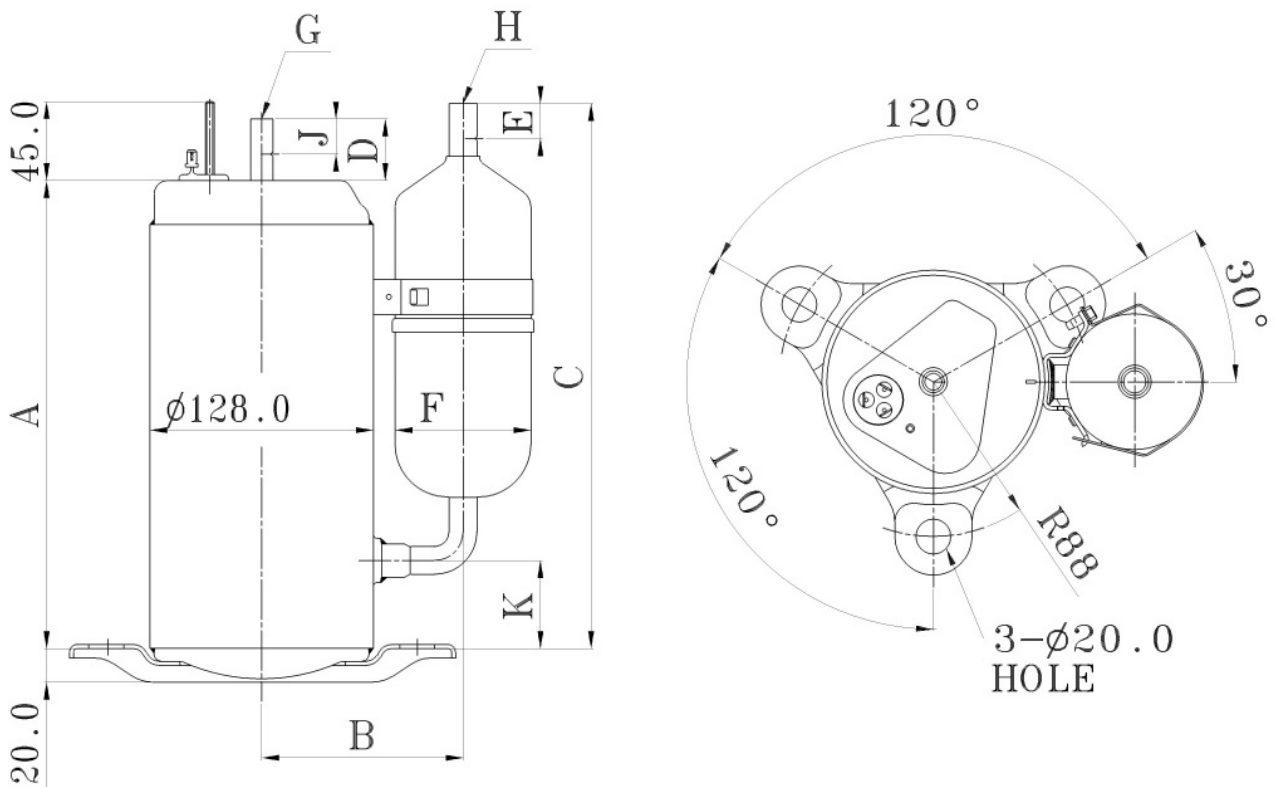

UNIT: mm (inch)

MODEL NO	DIMENSIONS							ACCUM (O,D) F	TUBE (I.D)	
	A	B	C	D	E	J	K		G	H
48B180JUBEH	273.4 (10.76)	114.5 (4.51)	311.2 (12.25)	35.0 (1.38)	15.0 (0.59)	15.0 (0.59)	51.2 (2.02)	77.4 (3.05)	9.70 (0.38)	12.85 (0.51)